



# Food Waste Steward™ Specification Sheet

Model CA-200-NR  
Designed for Quick Serve Restaurants

## Smallest & Fastest Commercial Grade Dehydrator

Provides on-site reduction of food waste volume - up to 90%. The residual dried food waste (DFW) can be used as either a valuable compost feedstock or in animal feed.

### Features & Benefits:

- Patent Pending dehydration design with significantly faster cycle times possible - 3 cycles per day
- 30"x30" footprint - Specifically designed for QSR
- UV technology for improved sanitation and odor mitigation.
- Vented and Non-vented remote options significantly reduce heat load in occupied space

### Easy Unloading

- Power activated discharge door
- Ergonomically designed to unload into 5 gallon container reducing strain on the operator.

### OUTPUT - Pathogen-Free Dehydrated Food Waste (DFW)

- High nitrogen content and can be used as soil amender for gardens, urban farms, and nurseries
- Nitrogen feedstock for composting
- Animal feed- high crude protein

### Manufacturing Expertise:

- 15 years of manufacturing experience
- Designed and manufactured in USA



**200 Pound Input = 20-60 Pounds Output**

**70 to 90% Reduction  
7-9 Hour Cycle Time**



For Video



SCAN ME



## Foodservice Sustainability Solutions

4986 Canton Road, Suite 200, Marietta, GA 30036

[greenteam@fs-sustainability.com](mailto:greenteam@fs-sustainability.com)

[www.fs-sustainability.com](http://www.fs-sustainability.com)

800.351.8875





## Food Waste Steward™



**Foodservice Sustainability Solutions**  
4986 Canton Road, Suite 200, Marietta, GA 30036  
[greenteam@fs-sustainability.com](mailto:greenteam@fs-sustainability.com)  
[www.fs-sustainability.com](http://www.fs-sustainability.com)  
800.351.8875

### INPUT - Front Load Up To 200lbs



### Interior Processing for 70 to 90% Reduction



### Control Panel

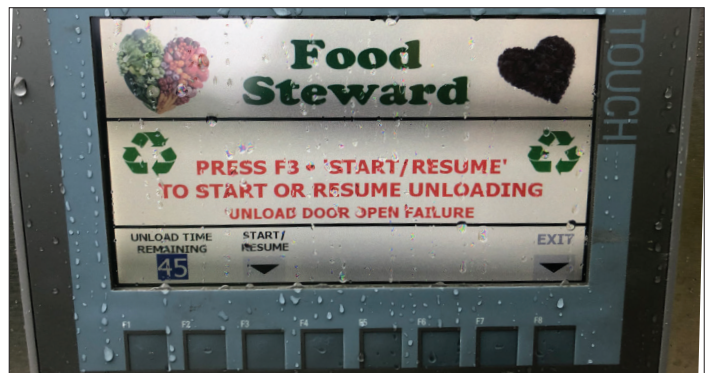

### OUTPUT - Pathogen-Free Dehydrated Food Waste (DFW)



# Food Waste Steward™ Specification Sheet

**Model CA-200-NR**  
**Designed for Quick Serve Restaurants**

### Electrical Specifications:

- 208V, Single Phase, 3 wire, 38A
- 230V, Single Phase, 3 wire, 40A

**Connections**  
**Vent or Drain Option**  
**View from above**

### Remote Cooling Unit Installation

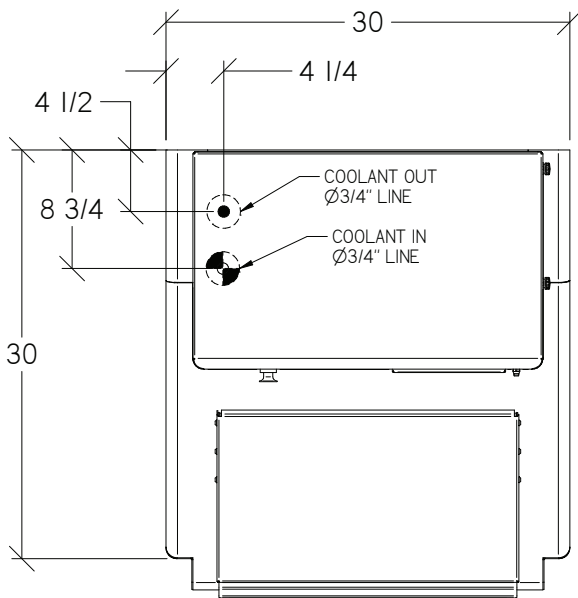
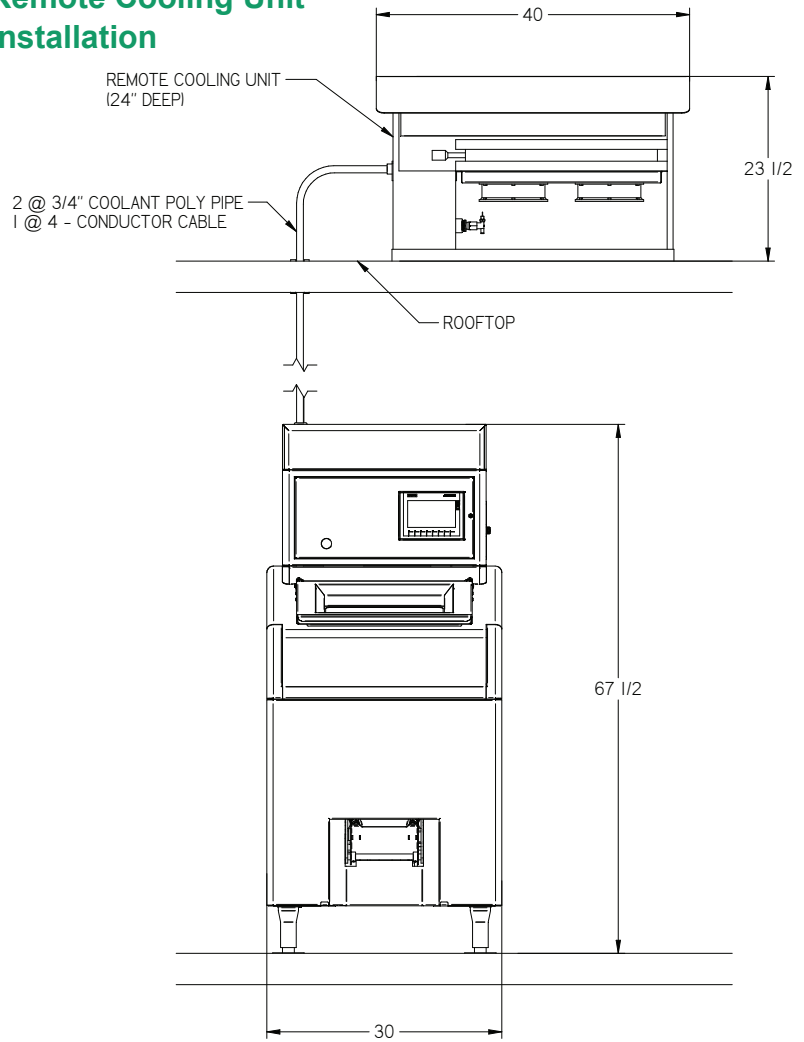

TOP VIEW  
CA-200-NR TOPSIDE CONNECTIONS

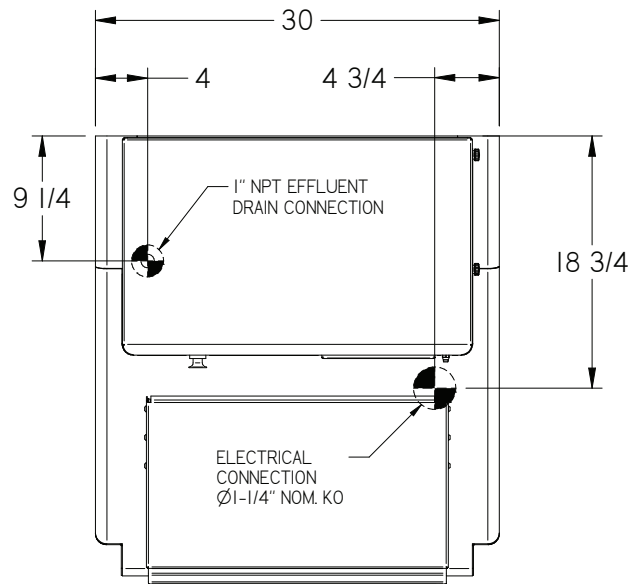

TOP VIEW  
CA-200-NR BOTTOMSIDE CONNECTIONS



# Food Waste Steward™ Specification Sheet

**Model CA-200-NR**  
**Designed for Quick Serve Restaurants**

Provides on-site reduction of food waste volume - up to 90%. The residual dried food waste (DFW) can be used as either a valuable compost feedstock or in animal feed.

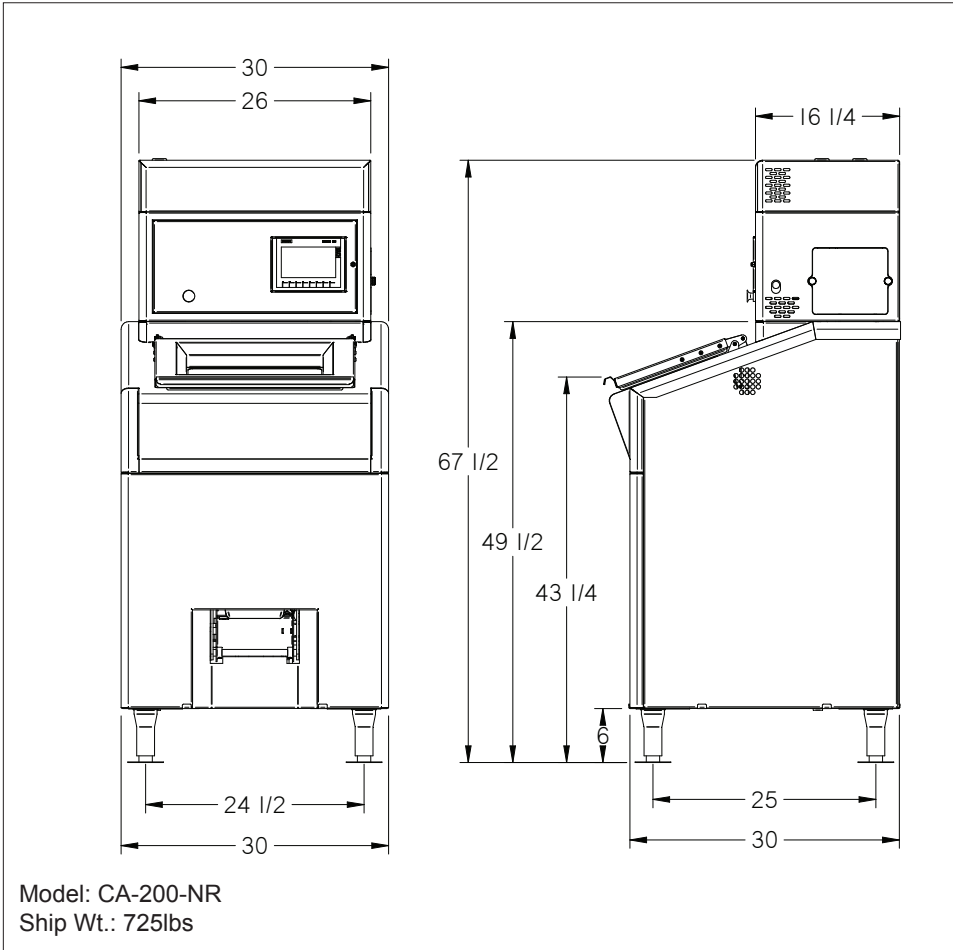

Model Number	Overall Dimensions						Approx. Ship Wt	
	Width		Length		Height			
	(in)	(mm)	(in)	(mm)	(in)	(mm)	(lb)	(kg)
CA-200-NR	30	762	30	762	67.5	1638	725	329