



Fully Automated Hands Free Motion Sensor Front of the House Trash Compactor

Specification Sheet

Features & Benefits:

- 4 loadings between automatic compaction.
- Contactless fully automated hands-free doorway motion sensor activated, easily opens with the motion of a hand or tray
- Dual action door opens contactless or pressure trigger back-up.
- Smart LCD shows compaction countdown and alerts at 80% and 100% fill rate
- Turn key to the right to open for a quick trash removal or to the left for one manual compaction
- Heavy duty stainless steel construction for better durability and ease of cleaning
- Easy-to-change slide in décor options, custom decor finishes also available
- Discarded trays stack on top of the unit with guard rails preventing slippage.

Easy Operation: Plug-n-Play

- Works with existing outlets - No special electrical required, 110 volts, 15 amps, ETL Listed

Manufacturing Expertise:

- 24 years of manufacturing excellence
- Designed and manufactured in USA



Scan to watch the video.



Foodservice Sustainability Solutions

4986 Canton Road, Marietta, GA 30066

greenteam@fs-sustainability.com

www.fs-sustainability.com

800.351.8875



Fully Automated Hands Free Motion Sensor Front of the House Trash Compactor



Discarded trays stack on top of the unit with guard rails preventing slippage.



Smart LCD shows when the unit is ready to use. Compaction countdown and alerts at 80% and 100% fill rate, 4 loadings deposits before compaction is required, 9 second compaction cycle



Smart LCD shows alert when unit is in 9 second compaction.

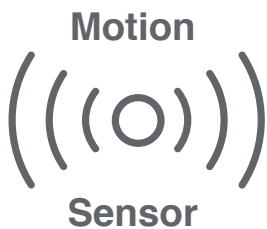

Contactless fully automated hands-free doorway motion sensor activated, easily opens with the motion of a hand or tray

Dual action door opens contactless or pressure trigger back-up.



Works with existing outlets - No special electrical required, 110 volts, 15 amps, ETL Listed

Match Your Store Décor

Your store design is very important to us, we want our Motion Sensor Front of the House Trash Compactor to blend in seamlessly into your store décor.

Each unit is constructed of heavy duty stainless steel for better durability and ease of cleaning.

Easy-to-change slide in décor options and custom decor finishes are also available

Easy to change, slide in décor options:

Top - Avonite Surfaces® - Acrylic solid surfaces offers a high end aesthetic, safe, durable and easy to clean

Base - Wilsonart or Nevamar - High pressure laminates, beautiful seamless finishes and easy to clean



Turn key to the right to open unit for a quick trash removal or to the left for one manual compaction.



Stainless Steel compactor trash bin

Standard Color Palette Selection

Top - Avonite® “Palermo”
Base - Wilsonart “Shaker Cherry”



Top - Avonite® “Altitude”
Base - Nevamar “Jute”



Top - Avonite® “Palermo”
Base - Wilsonart “Cafelle”





Fully Automated Hands Free Motion Sensor Front of the House Trash Compactor Specification Sheet

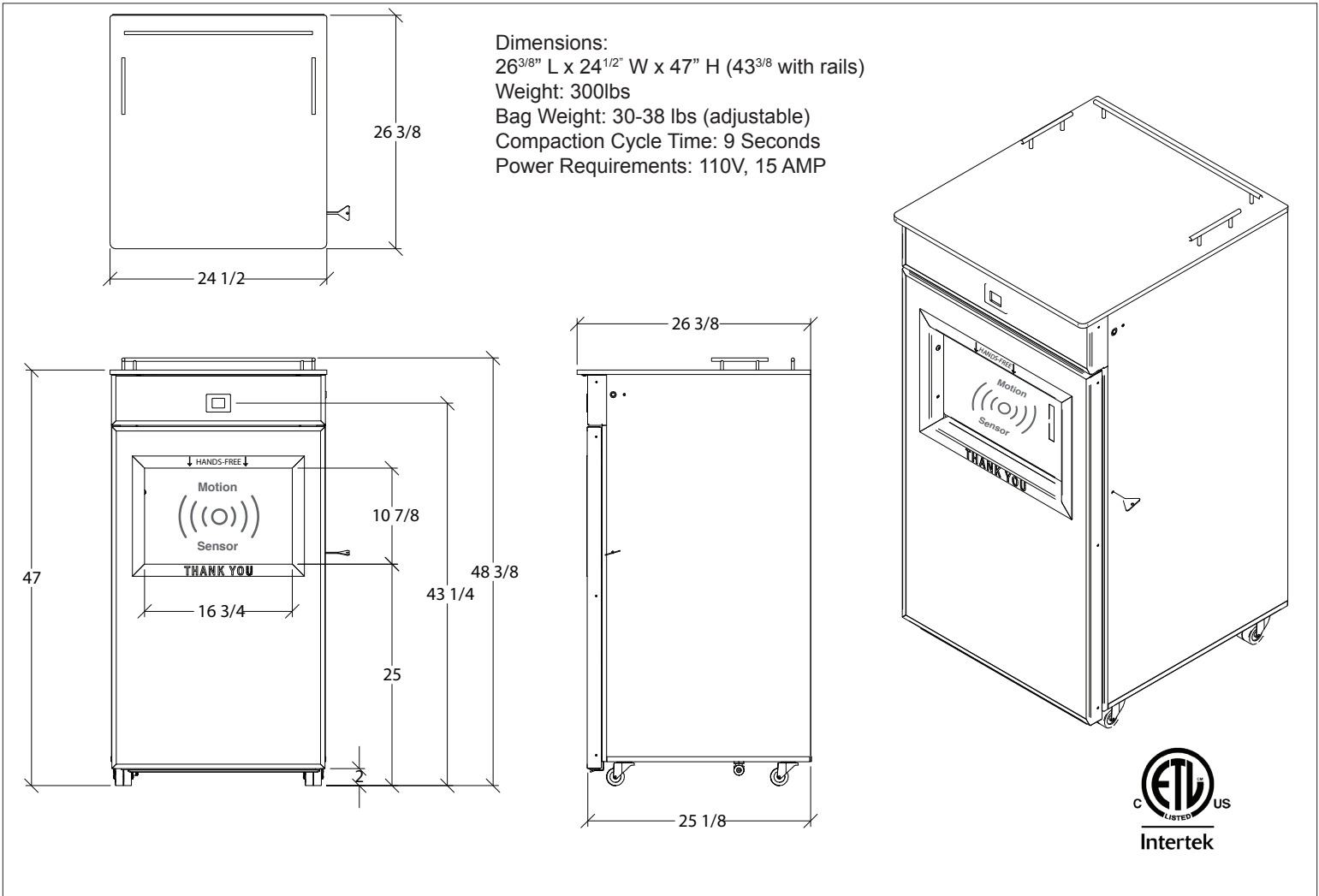

Warranty:

- Includes one-year parts and labor
- Optional Extended Warranty also available

Lease options available:
 3 Year Lease Purchase
 5 Year Lease Purchase

Testimonial

What our customers are saying

"Foodservice Sustainability Solutions FOH compactors are durable, easy to empty and clean, and very safe for both our customers and staff to operate."

