



*LED Touch Screen Command Center  
with security pass code to begin operation.*



*Briquettes are collected in two bottom trays. Up to 1800 soiled trays are easily loaded through a large forward facing door. Briquette below represents over 600 polystyrene trays.*



*Tap & Stack SmartCart is used for polystyrene tray collection.  
10<sup>3/4</sup>" W X 25" L X 39<sup>3/16</sup>" H*



*Briquettes measure  
15" W X 18" L X 2" H  
12lbs each*



## StyroGenie SG-1200 Specification Sheet

### Benefits:

- Recycles polystyrene foam, reducing waste volume by 95%
- Over 70% reduction in waste removal costs
- 100% diversion from landfill
- Quantitative CO2/GHG emissions reductions
- US Green Building Council Characteristic of a Green Institution has identified (13) characteristics - FSS waste reduction and recycling programs for polystyrene and food waste meet 8 of the 13.

### Safety Access Control:

- The SG-1200 includes an LED touch screen interface with 4 digit password protection and automatic locking, load and discharge doors to safely prevent unauthorized access and operation.

### Features:

- SG-1200 is constructed with 16 gauge type 304 #4 polished stainless steel interior and exterior
- 1800 soiled tray capacity.
- SG-1200 has a front facing/forward opening single door optional right or left hand opening.
- Both doors equipped with timed safety interlocks.
- Two (2) removable 14 gauge stainless steel catch pans with hemmed safety edges on all sides

### Options:

- Casters in Lieu of legs
- Power Vent with Odor Neutralizer
- Sorting table for collection and separation
- Tap & Stack Cart
- Start-up and Training

### FSS StyroGenie is an advanced Polystyrene Densifier:

Any soiled #6 polystyrenes can be processed - trays, cups, clamshells and utensils. The briquettes are converted into PS pellets or styrene oil for repurposing. In a two year period StyroGenie has diverted over 97,000,000 polystyrene trays from landfills and we will keep counting.

### Short Form Specification:

Constructed with 16 gauge type 304 #4 polished stainless steel interior and exterior with front facing opening single door with 3 stainless steel hinges. Door(s) to have timed safety interlocks. Will have 2 removable 14 gauge stainless steel catch pans with hemmed edges. Cabinet will be vented through interior sidewall and terminated into stainless steel collection cup. Will be controlled by intuitive pass code protected LED Command Center Touchscreen with step by step instructions for safe loading, processing and unloading. Capacity will be 1800 polystyrene foam trays with maximum 8 hour processing time and pass code safe to "Open Doors" button for unlocking door(s). Will have a 4 digit pass code to prevent unauthorized access and operation. Will have redundant high limit temperature sensors to prevent overheating with "Safe to Open" message from Command Center. It will be listed and labeled by Intertek. 120v, 18.8 amps. 25 amp circuit minimum, 8 foot cord and NEMA 5-30P plug. Castors or legs.

## Foodservice Sustainability Solutions, Inc.

1035 Cobb Industrial Dr., Marietta, GA 30066

[info@fs-sustainability.com](mailto:info@fs-sustainability.com)

[www.fs-sustainability.com](http://www.fs-sustainability.com)

Printed in the USA 5.2017

## Empowering Zero Waste!



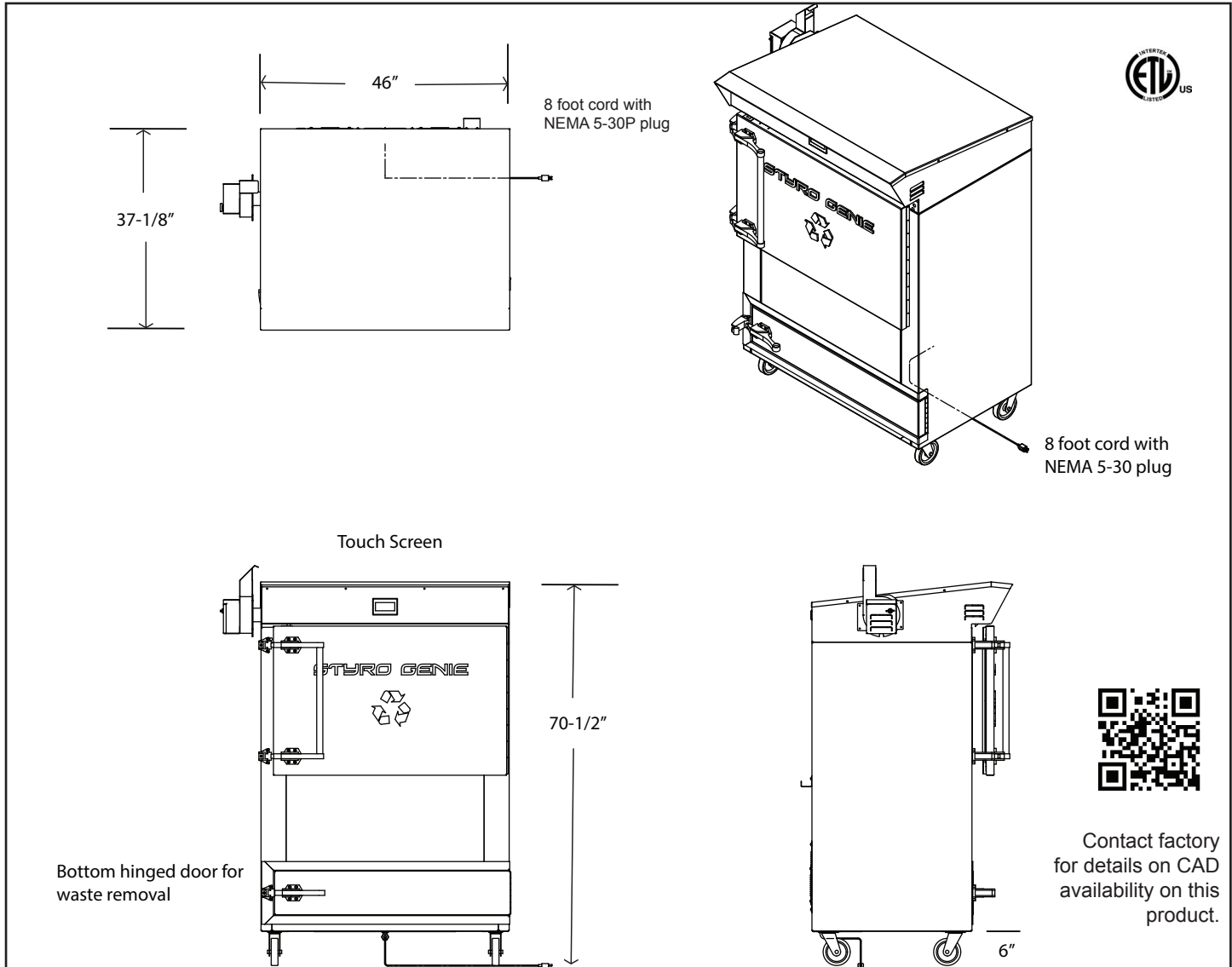

Model	Tray Capacity	Dimensions/Crated				Electrical		Processing Time
		Length	Depth	Height	Weight	Volts	Amps	
SG-1200	1800	46"	37-1/8"	70-1/2"	750lbs	120v	18.8 Amps 25 amp circuit minimum 8 Foot Cord & NEMA 5-30P plug.	8 hrs maximum
		62"	44"	78"	905lbs			

**Warranty:**

- Includes One-year parts and labor warranty.
- Optional Extended Warranty also available.

**StyroGenie Air Emissions:**

StyroGenie air emissions from thermal densification process have been 3rd party tested by two independent labs. All testing concluded that emissions met both the air quality standards of AIHA and the NELAC. Additionally, the StyroGenie meets emission standards of Cal/OSHA PEL (Permissible Emissions Limits).

**Foodservice Sustainability Solutions, Inc.**

1035 Cobb Industrial Dr., Marietta, GA 30066

[info@fs-sustainability.com](mailto:info@fs-sustainability.com)

[www.fs-sustainability.com](http://www.fs-sustainability.com)

Printed in the USA 5.2017

**Empowering Zero Waste!**

